

INVITATION FOR BIDS



PROFESSIONAL CONTRACTOR SERVICES DCDA METER VAULT @ EPOCH-CLEMSON

IFB 2021-006 SLW_EPOCH

**Due Date: October 15, 2021
3:00 PM EST**

**Seneca Light & Water
251 E. North Second Street
P.O. Box 4773
Seneca, South Carolina 29679**

THIS IS NOT AN ORDER

BID REQUEST NUMBER: IFB 2021-006
DATE OF INVITATION: October 7, 2021

QUOTES WILL BE RECEIVED AT:

Seneca Light & Water
251 E. North Second Street
P.O. Box 4773
Seneca, South Carolina 29679

UNTIL 3:00 P.M. LOCAL TIME ON **FRIDAY, October 15, 2021.**

Project Name:	<u>DCDA Meter Vault @ Epoch-Clemson</u>
Project Location:	<u>Jacobs Road</u>
City/County/State:	<u>Seneca / Oconee / South Carolina 29678</u>
Project Number:	<u>IFB 2021-006 SLW_EPOCH</u>
Response Deadline:	<u>October 15, 2021 3:00 P.M. EST</u>

INTRODUCTION

City of Seneca Light & Water (herein aka, SL&W / City / Owner / Engineering) is soliciting bids from qualified vendors for Professional Contractor Services for structural installation of a 'DCDA Meter Vault'. This is an invitation to submit bids to furnish the materials and/or services described herein.

Bids are to be submitted on the form contained herein (*see page 6*). Bids submitted via facsimile transmission shall be on company stationery and shall be the sender's responsibility for verification receipt of fax transmittal. Bid submittals for this project shall reference it as IFB 2021-006 SLW_EPOCH, and clearly label the envelope/page/sheets with the same reference. Bids must be complete and in U.S. dollars. See instructions and conditions enclosed herein.

NO BIDS BY EMAIL.

SL&W reserves the right to reject any and all bids, or any part thereof, negotiate changes in bid, accept any bid or any part thereof, waive minor informalities or defects in any bid, and not to award an Agreement/Contract if it is in its best interest.

SL&W shall not be held responsible for Responder's lack of understanding of what is required by this solicitation. Should a responder not understand any aspect of this request or require further explanation or clarification regarding the intent or requirements, it shall be the responsibility of the responder to seek guidance from SL&W's designated representative.

An Agreement/Contract resulting from this solicitation may be awarded to the responsive Responder whose bid conforming to this solicitation appears to be the most advantageous to SL&W.

This solicitation is not to be construed as a commitment of any kind nor does it commit Seneca Light & Water to pay for any costs incurred in the submission of an offer or for any other incurred cost. BIDDER/RESPONDER TERMS AND CONDITIONS: PROSPECTIVE BIDDERS ARE CAUTIONED TO PAY PARTICULAR ATTENTION TO THIS CLAUSE. Bidder/Contractor imposed terms and conditions which conflict with the terms and conditions of this IFB are considered counter offers and, as such, will cause SL&W to consider the quote non-responsive.

If a Responder attaches additional terms and conditions as part of its bid, such attachments must be accompanied by a disclaimer stating that in the event of conflict between the terms and conditions of this IFB and the terms and conditions of the Bidder; the terms and conditions will prevail.

Seneca Light & Water reserves the right to reject any or all bids, waive informalities and minor irregularities, if such action is in its best interest.

Direct all questions to:

Jeremy Wirtz
Engineering Technician
P.O. Box 4773, Seneca, SC 29679
864.710.3696 cell
864.882.8457 office
864.885.6012 fax
Email: jwirtz@seneca.sc.us

Relevant questions must be submitted prior to 4:00 pm E.S.T. Thursday, October 14, 2021. Questions submitted after that date and time will not be due a response.

SCOPE OF WORK

1. DESCRIPTION OF SOLICITATION

Seneca Light & Water seeks to receive bids for professional contractor services to construct to completion the installation of a 'master water meter vault' located at the Epoch-Clemson Student Housing complex on Jacobs Road, Clemson, South Carolina 29672.

Contractors qualified and interested are requested to submit a bid proposal to:

- a. Provide, deliver, and fully warrant installation of Master Water Meter Vault as prescribed.
- b. Include all costs for labor, materials, tools, abatement, permits, licenses, and equipment necessary for the completion of repairs to the facility.

2. PROJECT DESCRIPTION

The following is the projected 'Scope-of-Work', but is not limited to:

- Construct and prepare site at the designated location.
- Install a new prefabricated concrete water meter vault per the attached 'Exhibit A', as directed by SL&W.
- The new vault shall be installed, per SL&W, at the designated location; and installation must allow for the continued use of fire line and domestic water main during construction.
- Vault shall include 6-inch DCDA with meter.
- See Exhibit 'A' for configuration of connection to existing 10-inch water main.
- Contractor may be required to make the final tie-in during hours that will minimize impact.
- Contractor will coordinate all activities with SL&W and will be responsible for locating all underground utilities.
- Complete project and re-dress site.
- Removal and proper disposal of all trash and debris associated with the project.
- Contractor at its own expense shall promptly remedy and repair all damages or loss to any property caused in whole or part by its employees, subcontractor(s), supplier, or anyone directly or indirectly employed by either of them, or by anyone for whose acts either of them may be liable.

KEY TASKS:

- After the contract is awarded, the Contractor's responsibilities will include all construction services necessary to complete the project as identified.
- Contractor shall be responsible for all required fees and permits.
- It is recommended each responder examine the premises to determine the extent of the work involved and the conditions under which the work will be performed.
- By submission of a bid proposal/quotation, it shall be construed as evidence that such examination has been made and no subsequent allowance will be acceptable in this connection.

3. ADDITIONAL REQUIREMENTS

- 3.1** The selected Contractor shall possess the appropriate license and registration required for this Project; have appropriate safety and emergency procedures; and key personnel may be required to pass background check.
- 3.2** All work performed shall follow appropriate OSHA standards, Federal, State, County, and local ordinances/regulations. The selected Contractor shall obtain all required licenses, permits, and/or certifications.
- 3.3** All work performed and completed in accordance with a valid Agreement /Contract will be subject to the acceptance of the City of Seneca by its authorized representative.
- 3.4** The Contractor shall deliver to SL&W, *upon award of a Contract/Agreement*, a certificate of insurance, and may be required to name the City (*Owner*) as an additional insured party in

amounts requested by the Owner and all insurance policies shall be maintained for the life of the contract. The City may require it be named as “ADDITIONAL INSURED” for its interest on all policies of insurance except Worker’s Compensation, Automobile Liability, and Professional Errors and Omissions, as regards ongoing operations, products and completed operations, and this shall be noted on the face of the Certificate of Insurance. As part of the certificate of insurance requirement the Contractor shall also include acknowledgement and acceptance of the waiver of subrogation provision granted to the City. This acknowledgement and acceptance should be included in the same section of the Certificate of Insurance that evidences the “Additional Insured” provision. The Contractor shall not allow any subcontractor to commence work on its subcontract until all similar insurance required of the subcontractor has been obtained.

3.5 The selected Responder shall procure, maintain, and provide proof of insurance coverage for injuries to persons and/or property damage as may arise from, or in conjunction with, the work performed on behalf of the Owner by the Contractor, his agents, representatives, employees, or subcontractors. Proof of coverage as prescribed herein shall be submitted prior to the commencement of work and such coverage shall be maintained by the Contractor for the duration of the contract period.

4. PROPONENT DECLARATION

4.1 By submittal of a bid the Responder declares to be fully informed and satisfied that the Scope-of-Work is a bases used to obtain submitted price quote; therefore, it is understood that actual quantities may be subject to adjustment by either increase or decrease, as deemed necessary, per conditions encountered during project construction and agreed by both the Contractor and SL&W (*its representative*). And should the quantities of work items be decreased or increased; the actual work quantity shall be completed at the unit prices stated therein.

4.2 SL&W shall be ‘held harmless’ for the Responder’s lack of understanding of what is required by this solicitation. Should a Responder not understand any aspect of this request or require further explanation or clarification regarding the intent or requirements, it shall be the responsibility of the Responder to seek guidance from the SL&W’s designated Representative.

4.3 The drawings, specifications and addenda are complementary of each other, what is called for by one shall be as binding as if called for by all. If a conflict arises between the drawings, specifications, and/or addenda, the problem shall be referred to SL&W for resolution

PROPOSED SCHEDULE

IFB Issued	Thursday, October 7, 2021
End of Question Period - 4:00 pm	Thursday, October 14, 2021
Responses Due by 3:00 pm	Friday, October 15, 2021
Notice of Intent to Award	Tuesday, October 19, 2021

DEFINITIONS

Agreement/Contract means a binding written instrument, executed by Owner and Contractor, that sets forth the Contract Price and Contract Times, identifies the parties and the Engineer, and designates the specific items as the entire and integrated written contract between the Owner and Contractor concerning the Work so designated and which together comprise the Agreement/Contract.

Bid /Proposal/Quotation means the written offer of a Bidder submitted on the prescribed form setting forth the prices for the Work to be performed.

Contractor means the person(s), firm(s), or corporations(s) selected, by the Owner, to carry out all duties, obligations, work, and service described in the IFB and all associated documentation, which may also include mutually agreed revisions subsequent to the submission of a bid. Both “Contractor” and “Responder” are complementary in terms of duties, obligations, and responsibilities at the IFB stage, through evaluation process, execution, and delivery of the services.

Drawings are part of the Contract that graphically shows the scope, extent, and character of the Work to be performed by Contractor.

IFB (Invitation for Bid) shall mean the solicitation of cost estimates to complete a designated work; including complete set documents, specifications, drawings, and addenda incorporated therein, and included in the IFB.

Laws and/or Regulations includes any and all applicable laws, statutes, rules, regulations, ordinances, codes, and orders of any and all governmental bodies, agencies, authorities, and courts having jurisdiction.

Owner means the individual or entity (*its authorized representative*) with which Contractor has contracted regarding the Work, and which has agreed to pay Contractor for the performance of the Work, pursuant to the terms of the Agreement/Contract.

Responder / Bidder / Proponent means an individual or entity that submits a Bid to Owner.

Services means and includes the provision by the selected proponent of all services, work, duties, and expectations as further described in the RFP. This will also mean the whole of the work, tools, materials, labor, equipment, travel, and all that is required to be completed and furnished by the Contractor.

Shall / Must / Will / Mandatory means a requirement that is required to be met.

SL&W means the City of Seneca Light & Water Department and its authorized representative.

Supply / Provide shall mean supply and pay for and provide and pay for the equipment, goods, materials, or other items to be provided by the Contractor/Vendor to the Owner under the Agreement/Contract.

EXHIBIT 'A'

AND

BID FORMS

BID FORM - A: CERTIFICATION REGARDING DEBARMENT & OTHER RESPONSIBILITY MATTERS

BID FORM - B: BIDDER'S QUESTIONNAIRE

BID FORM - C: TOTAL BID AMOUNT

6" DCDA WITH METER

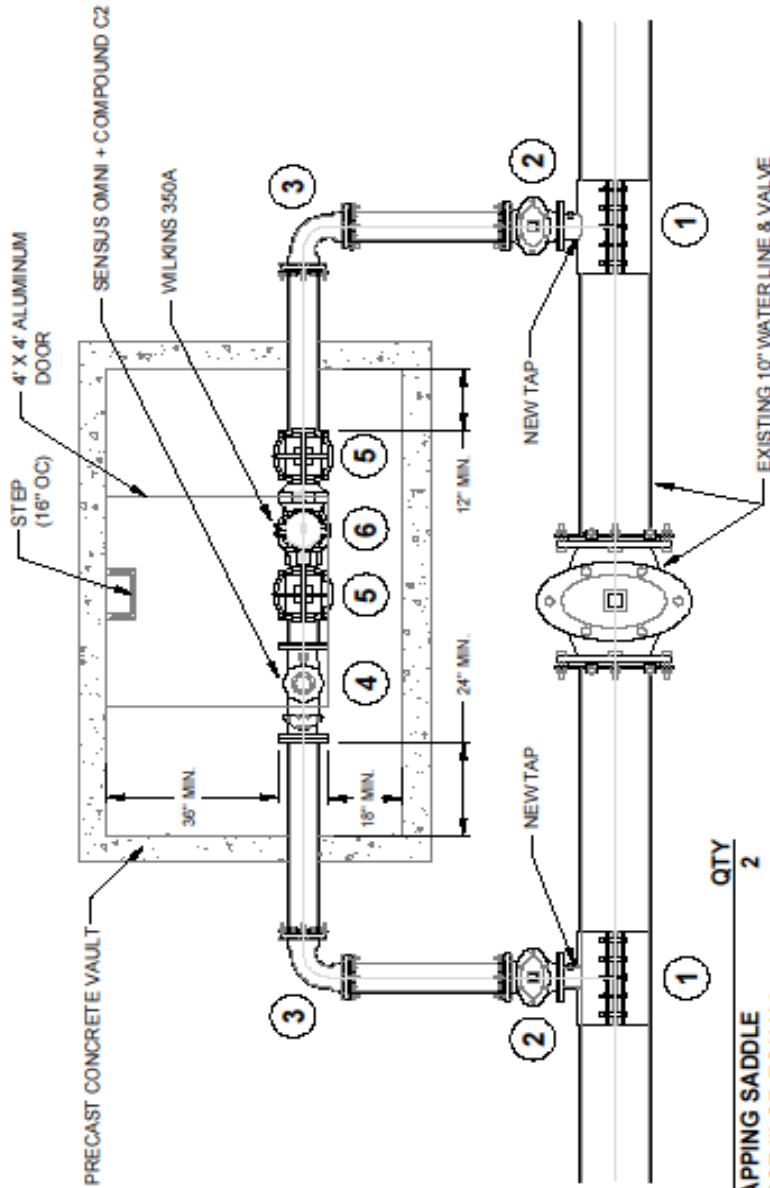

PART	QTY
1. 10"x 6" TAPPING SADDLE (ROMAC SST III OR EQUAL)	2
2. 6" TAPPING VALVE	2
3. 6" MECHANICAL JOINT 90'	2
4. 6" COMPOUND WATER METER	1
5. 6" FLANGED GATE VALVE (OUTSIDE SCREW & YOKE)	2
6. 6" DOUBLE CHECK VALVE	1

NOTE:
 - 10" WATERLINE & GATE VALVE ARE EXISTING
 - SIZE ALL MATERIALS ACCORDINGLY
 - MEGALUGS RESTRAINTS REQUIRED ON MECHANICAL JOINTS
 - VAULT SIZE TO BE DETERMINED BY DESIGN ENGINEER
 - ADJUSTABLE PIPE SUPPORTS TO BE USED UNDER ASSEMBLY

CONTACT: JEREMY WIRTZ : (864)710-3696
 SCOTT MCLANE : (864)710-8850

NO.	DATE	REVISIONS	BY

SENeca LIGHT AND WATER PLANT
 P.O. BOX 4773
 SENECA, SOUTH CAROLINA 29679-4733
 (864) 885-2724

Light & Water

SEE PROJECT: EPOCH MASTER METER PIT

SCALE: (AS SHOWN) DRAWN BY: LGB DATE: 8/7/21 SHEET: 1 OF 1

BID SUBMISSION FORM

Certification Regarding Debarment & Other Responsibility Matters

Signed copies of the Certification Regarding Debarment and Other Responsibility Matters must be included in the proposal package.

By submitting a bid, the Responder certifies, to the best of his/her knowledge and belief, that:

- I. Responder and/or any of its Principals
 - (A) Are not presently debarred, suspended, proposed for debarment, or declared ineligible for the award of contracts by any state or federal agency.
 - (B) Have not, within a three-year period preceding this bid, been convicted of or had a civil judgment rendered against them for: commission of fraud or a criminal offense in connection with obtaining, attempting to obtain, or performing a public (Federal, state, or local) contract or subcontract; violation of Federal or state antitrust statutes relating to the submission of quotes; or commission of embezzlement, theft, forgery, bribery, falsification or destruction of records, making false statements, tax evasion, or receiving stolen property; and
 - (C) Are not presently indicted for, or otherwise criminally or civilly charged by a governmental entity with, commission or any of the offenses enumerated in paragraph I (B) of this provision.
- II. Responder has not, within a three-year period preceding this offer, had one or more contracts terminated for default by any public (Federal, state, or local) entity.
 - (A) The word "Principals," for the purposes of this certification, means officers; directors; owners; partners; and persons having primary management or supervisory responsibilities within a business entity (e.g., general manager; business manager; head of a subsidiary, division, or business segment, and similar positions).
 - (B) Responder will provide immediate written notice to the Owner if, at any time prior to contract award, Responder learns that its certification was erroneous when submitted or has become erroneous by reason of changed circumstances.
 - (C) If the Responder is unable to certify the representations stated in paragraphs (I), Responder must submit a written explanation regarding its inability to make the certification. The certification will be considered in connection with a review of the Responder's responsibility. Failure of the Responder to furnish additional information as requested by the Owner may render the bid as non-responsive.
 - (D) Nothing contained in the foregoing shall be construed to require establishment of a system of records in order to render, in good faith, the certification required by paragraph (A) of this provision. The knowledge and information of a Responder is not required to exceed that which is normally possessed by a prudent person in the ordinary course of business dealings.
 - (E) The certification in paragraph I (A) of this provision is a material representation of fact upon

which reliance was placed when making award. If it is later determined that the Responder knowingly or in bad faith rendered an erroneous certification, the Owner may terminate, for default, any Contract resulting from this solicitation, and in addition to other remedies available to the City of Seneca.

- (F) By signing, I certify that this bid is made without prior understanding, agreement, or connection with any corporation, firm, or person submitting a bid for the same project, materials, supplies, or equipment, and is in all respects fair and without collusion or fraud. I understand that collusive bidding is a violation of State and Federal law and can result in fines, prison sentences, and civil damage awards. I agree to abide by all conditions of this bid and certify that I am authorized to sign this bid for the responder.

Authorized Signature

Date

BID SUBMISSION FORM

**SENECA LIGHT & WATER
IFB 2021-006 SLW_EPOCH
PROFESSIONAL CONTRACTOR SERVICES
DCDA METER VAULT @ EPOCH-CLEMSON**

BIDDER'S QUESTIONNAIRE

Note: Failure to provide the information requested in this questionnaire may be cause for rejection of the solicitation on the basis of non-responsiveness.

Name of Your Business: _____

Street Address: _____

Mailing Address if Different: _____

City: _____ State: _____ Mailing Zip: _____

Telephone: _____ Fax: _____ E-Mail: _____

How many years has the business been under the above name? _____

Previous business name(s) if any: _____

My Bid Acceptance Period is _____ Days. *(Quotes providing less than thirty (30) calendar days for acceptance may be considered non-responsive and may be rejected.)*

Are you acting as a broker or the primary supplier in this transaction?

- Primary Supplier
- Broker

Business Information *(Please check all that apply):*

- My business is Individual
- My business is a Partnership
- My business is a Non-Profit
- My business is a Joint-Venture
- My business is a Corporation incorporated under the laws of the State of _____
- My business is full-time
- My business is part-time

Bidder shall list any variations from or exceptions to the Terms, Conditions or Specifications of the Solicitation:

Completed by: _____ Title: _____

Signature: _____ Date: _____

BID SUBMISSION FORM

**SENECA LIGHT & WATER
IFB 2021-006 SL&W_EPOCH
PROFESSIONAL CONTRACTOR SERVICES
DCDA METER VAULT @ EPOCH-CLEMSON
TOTAL BID AMOUNT**

By submission of this bid, the respondent certifies, and in the case of a joint bid, each party thereto certifies as to its own organization, that this bid has been arrived at independently, without consultation, communication, or agreement as to any matter relating to this bid, with any other bidder or with any competitor.

The bid listed below must include all applicable cost relevant to demolition, excavation, disposal, construction, and delivery to site destination: Jacobs Road, Seneca, South Carolina 29678; and comply with the specifications or include detail specifications for optional recommendation.

Base Unit (Price must include all materials, tools, appurtenances, specifications, and warranty)

TOTAL BID _____ **Dollars** (\$ _____)

Amounts are shown both in words and figures; if any discrepancy, the amount shown in words shall govern. The above bid amount includes all labor, materials, and equipment, as required; cleaning, removal, overhead, profit, fees, insurance, etc., to cover the several kinds called for.

COMPANY NAME

SIGNATURE BY AND FOR THE BIDDER

COMPANY ADDRESS

PRINTED NAME OF ABOVE BIDDER

DATE OF QUOTE

CONTACT PHONE NUMBER

CONTACT EMAIL

City of Seneca reserves the right to reject any or all bids and to waive any irregularities as deemed necessary and in its best interest.